

# StockBox

from source to sale

The StockBox is a wheeled folding bulk container for the transportation of products direct from source, through the supply chain to store display, eliminating the need for hand merchandising. The unit folds down to aid vehicle cude and storage optimisaition when empty.

source → supply chain → store display

RTP trays may be stacked on top of constructed unit to aid vehicle utilisation and enable suppliers to dispatch assembled store orders.



## Specifications & Dimensions

Description	800x600mm Bulk Display Unit (BDU)
Colour	Black as standard
Dimensions	Width 868mm Depth 600mm Height 1070mm (constructed) 684mm (folded)
Weight	26.5kgs +/- 3%
Nominal Load Capacity	CHEP recommends a maximum load of 300kg - 340 litres
Material	BDU: Polyethylene (PE) Castors: Polyamide-Resilex sandwich. Two fixed, two swivel and diameter is 100mm Point of sale holder: Nylon
Temperature Range	-25°C to + 40°C (Please consult CHEP for specific advice)
Non Approved Substances	BDU should not come into direct contact with the following substances: Benzene based compounds, Chlorine based compounds, Oleum, Nitric Acid, Bromic Acid, Methyl Bromide. (Please consult CHEP for specific advice)
User's Responsibility	It is the responsibility of all users and hirers to ensure that any other users to whom they pass on the BDU are advised of the contents of this specification sheet. Users are also responsible for completing assessments of Safe Systems of Work and Risk Assessments prior to using the equipment



Stockbox once folded

**StockBox**

### StillageNet Materials Handling

StockBox is distributed exclusively in the UK and Europe by StillageNet. StillageNet is also the largest supplier of portable rental racking systems in the UK. All StockBox are available for both long and short term hire, providing a cost effective solution to fluctuating production and storage demands. Hire it when you need it, de-hire it when you don't. For more information on StockBox and other StillageNet products call 0800 735 1039 or visit [www.stillage.net](http://www.stillage.net)

StillageNet is a trading name of Network Distribution Ltd. Company Registration No. 74324 VAT Registration No. 678 6794 53

# StockBox

from source to sale

## ? Why choose StockBox?

### Ideal for In-store Display

- Enables consistent product presentation in all stores
- Ideal for use as a merchandisable unit
- Display in store is not dependent on the shelf replenisher

### Easy Access to Product

- Two position door lowers to 66% enabling both ease of packing at supplier and consumer access to product in store

### Supply Chain Optimisation

- Use throughout the supply chain in place of roll cages and pallets and as a merchandisable unit
- Trays can be stacked on top of the BDU to further aid vehicle utilisation and enable store order picking at the supplier
- Eliminates need for product handling between point of packing and point of sale, thereby reducing product damage

### Ease of Handling

- Easy and safe to move manually with appropriate mechanical handling equipment
- Reduced handling through cross docking and one touch replenishment

### Loading

- Can hold up to 300kg of product, with internal volume of 340 litres
- Can be double stacked when full to aid storage and vehicle utilisation

### Foldable and Stackable

- Folds inward non sequentially to create a self-contained flat unit with no loose parts
- Ensures improved space utilisation during warehousing and transport
- Grab handles and 4-way entry base enable stacking manually or with appropriate mechanical handling equipment



Specifications

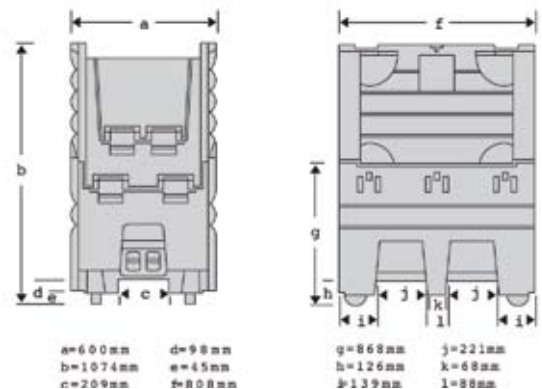

Folded StockBox

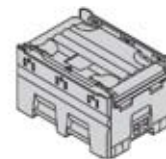

Constructed StockBox

### StillageNet Materials Handling

StockBox is distributed exclusively in the UK and Europe by StillageNet. StillageNet is also the largest supplier of portable rental racking systems in the UK. All StockBox are available for both long and short term hire, providing a cost effective solution to fluctuating production and storage demands. Hire it when you need it, de-hire it when you don't. For more information on StockBox and other StillageNet products call 0800 735 1039 or visit [www.stillage.net](http://www.stillage.net)

StillageNet is a trading name of Network Distribution Ltd. Company Registration No. 74324 VAT Registration No. 678 6794 53

**StockBox**